



Evorail Front-Fix

Guardrail has Evolved



Introduction



- About Evorail Front-Fix System
- Legislation & Hierarchy of Fall Protection
- Evorail Front-Fix System
- Evorail extra components
- Installation procedures

About Evorail Front Fix System



Evorail Front-Fix System

Evorail has its very own aesthetically pleasing unique design which makes it the preferred system of choice in fall protection

Evorail system provides a permanent edge protection and provides full protection where access is required for public use, maintenance or emergency purposes.

The strength, stability and safety of Evorail is second to none.

Evorail is Robust

All of the systems fixings are grade A2 stainless steel, its extra smooth galvanized finish (EN ISO 1461) gives Evorail a minimum lifespan of at least 25yrs as a maintenance free system .

Evorail is Modular

The system consists of galvanized pre-assembled uprights and 2.5mt rails. The 2.5mt hand and knee rails are connected with the Evorail Eazy clamp upright, which is fast, straightforward and easily adjustable to provide that perfect level finish.

Legislation & Hierarchy of Fall Protection

EN 13374:2004

All guardrails should be tested and designed to Temporary Edge Protection EN 13374 .

The Legislative Requirements:

- An edge protection system shall comprise at least a principal and an intermediate guardrail or intermediate protection, and it shall be possible to attached a toe board.
- The inclination of edge protection system class A shall not deviate from the vertical by more than 15 degrees.
- If an intermediate guardrail is provided, any gap shall be so dimensioned that a sphere of 470mm diameter will not pass through the protection.
- The distance between the uppermost part of the edge protection and the working surface shall be at least 1.0m measured perpendicular to the working surface.
- A load test of 0.30kN is applied horizontal from the rail and should not deflect more than 55mm.
- A load test of 1.25kN is applied vertically from the top rail and should not tip / fall over.



Legislative Hierarchy



The hierarchy for managing and selecting equipment for working at height is as follows.

Duty holders must ensure that:

- Where possible to avoid working at height.
- When working at height, work equipment is provided to avoid the risk of any fall.
- Where the risk of a fall cannot be avoided, use work equipment or other measures to minimise the distance and consequences of a fall should one occur.

When working at height, the duty holders must ensure when selecting the correct equipment.

- To use the most suitable equipment
- Give guardrails priority over personal protection such as harnesses and lanyards.
- Take account of the working conditions and the risks to the safety of all those at the place where the work equipment is to be used.

EVORAIL Front-Fix

Evorail Front Fix is a bespoke product, generally used when roof space is an issue and a parapet system cannot be used. This system is extremely flexible and can be adapted to provide a solution if our more popular versions cannot be used.

Evorail Front-Fix can be purchased in;

- ✓ Galvanized
- ✓ Aluminium
- ✓ 304 & 316 Stainless Steel

Component / Product code

Long upright – ERSLU

2.5mtr rail – ERAIL



Extra Components

Freestanding End

A freestanding end is used when the system finishes and there is no option to secure the rails to a permanent fixture.

A freestanding end consists of;

- the D end

Freestanding ends are available in;

- ✓ Galvanized
- ✓ Aluminium
- ✓ Stainless Steel

D ends are utilized to suit all of the Evorail systems.

Components / Product codes

D end – ERDEN

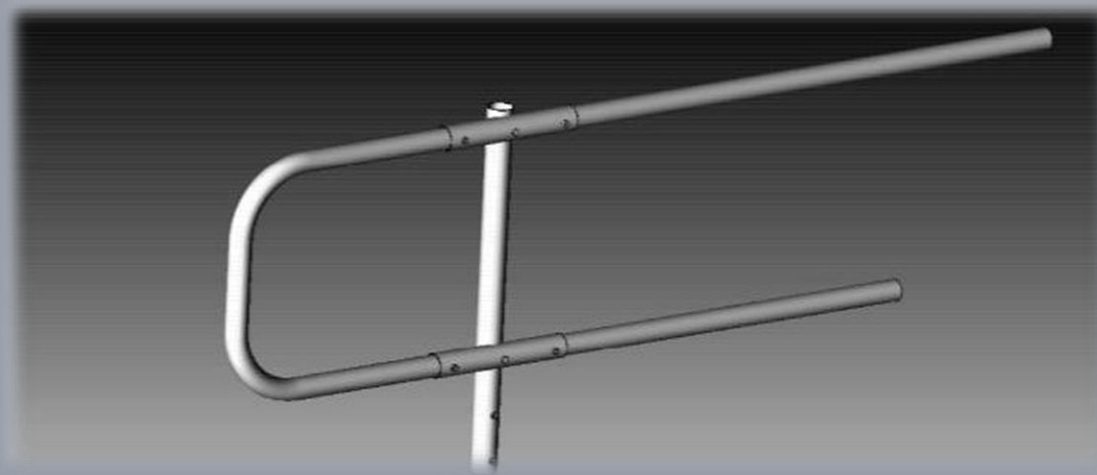

Extra Components

sweeping bend



A sweeping bend is the required component to accommodate design layouts with 90° corners.

Available in;

- Galvanized
- Aluminium
- Stainless steel

Component / Product code
Sweeping bend - ERSWB

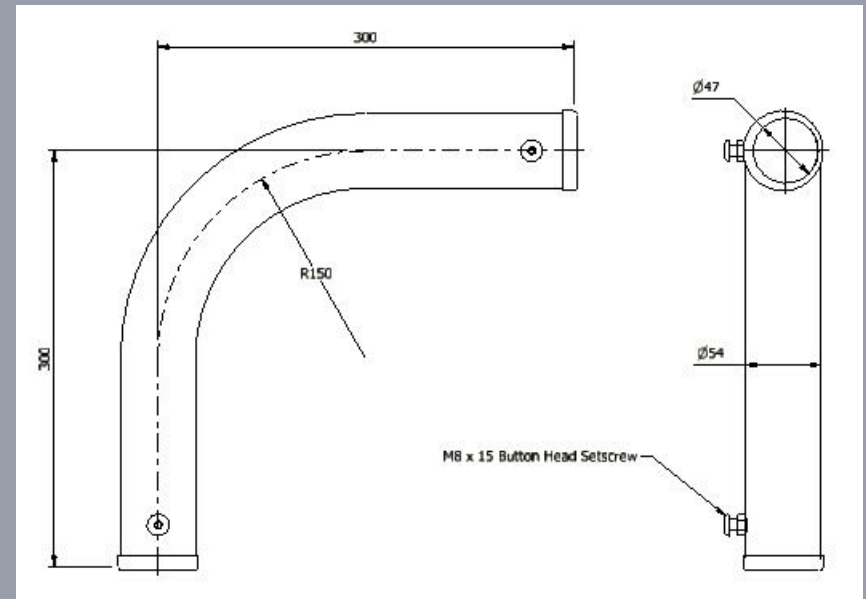

Extra Components

wall bracket



Wall brackets are the means to secure and connect the rail to a permanent fixture.

Available in;

- Galvanized

Component / Product code

Wall bracket - ERWBK

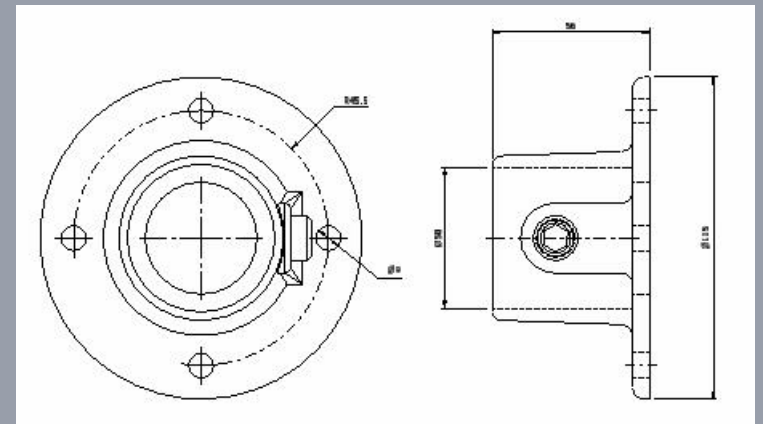
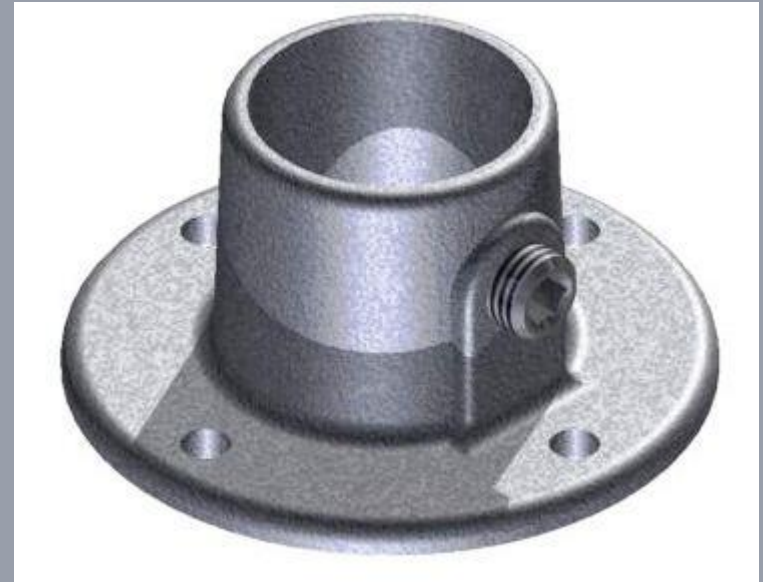

Extra Components multi-bend



A Multi-bend is the component which required to accommodate design layouts with corners other than 90°

Can also be used to overcome changes in roof levels.

Available in;

- Galvanized only

Component / Product code
Multi-bends - ERMUB

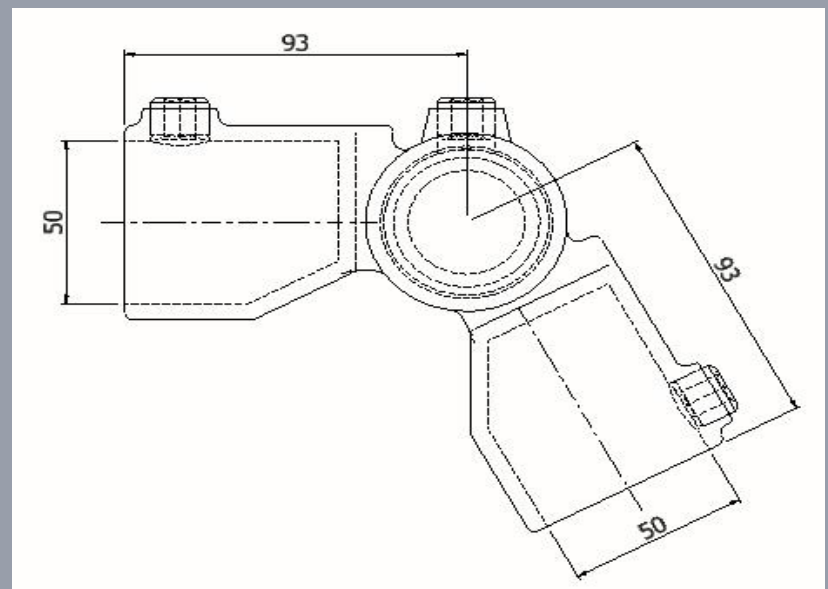
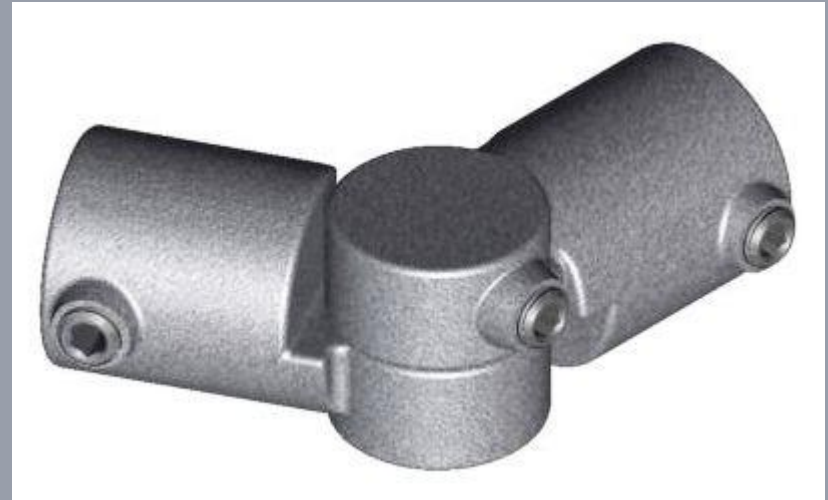

Extra components

T – piece

The T piece is used in conjunction with the double weight connector bar. And can be used to enable a variety of solutions on complicated roof layouts.

Available in;

- Galvanized only

Component / Product code

T – piece - ERTPI

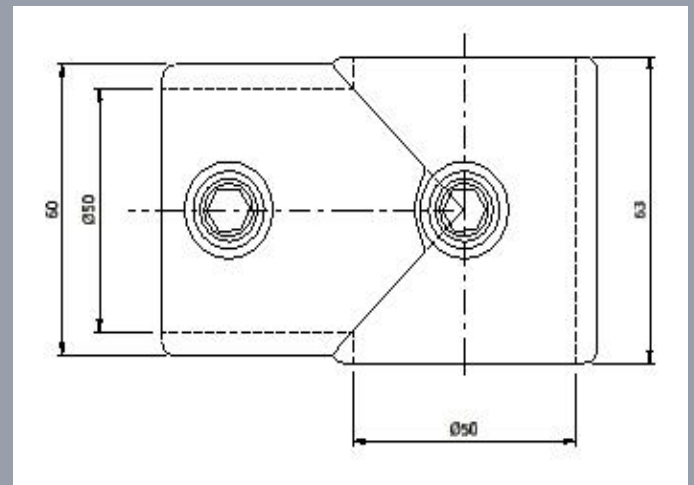

Extra Components

swinging gate

Swinging gate allows you to safely gain access through the Evorail systems, and to secure them behind you.

Available in;

- Galvanized
- Aluminium
- Stainless steel

Component / Product code
Swinging gate - ERSWG

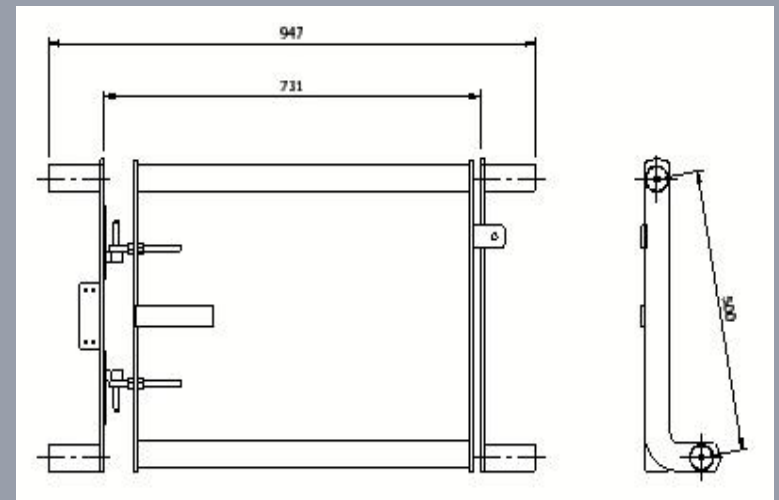

Installation Guide



Tools required for Evorail Front-Fixed



Tools you will need to install Evorail Top Fixed.

- ✓ 5mm allen key
- ✓ 8mm allen key
- ✓ Hacksaw or electrical cutting machine
- ✓ Battery drill
- ✓ Suitable drill bit to fix wall bracket (6mm masonry or 5mm steel bit)
- ✓ 13mm ratchet & spanner
- ✓ Marker pen
- ✓ Appropriate spanners, drill bits and fixings dependant on the individual roof application.

Planning your layout



- There will be 2 ways of accessing the components onto the roof:
 - Manually
 - Crane or hoist
- Once all the components are on the roof, you can start planning the layout and the erection of Evorail.
- Ensure the roof area of where the system is being installed is clear from debris and is free from any gravel or stones.
- Before you start to layout the system, plan your starting point. If there's a fixed end or D end that's probably the best place to start, and work from left to right.
- If the layout connects back to itself i.e. a square. Start at one of the corners with a long upright approximately 1m in from the corner.
- When your starting point has been decided, begin to layout the 2.5mt rails on the roof where the system is going to be erected, when all laid out begin to place the uprights at the joints of the rails.
- All sweeping bends should be placed at the appropriate corners.

Continued....



- Now all the system is laid out and ready to be erected. Go to your starting point and place the Front Fixed lower upright in position and fix appropriately to wall. Then slide in the upper upright section, and slide the knee rail into the upright. Then slide the top rail into the upright, holding the rails horizontal slide over the next front fixed upright placing the rails in at the same time.
- tighten up the M8 fixings with your 5mm allen key, you now have the first 2.5m section in place.
- Check that all is well and the 2no uprights are in the correct position. It's advised at this stage to double check everything is correct.
- Take the next rail and slide into the uprights knee rail socket, take the other rail and insert the front rail. An upper upright then slides over the rails, and fix upright as previous and tighten M8 bolts.
- Then ensure this section is level, slide into lower Front Fix upright and fix to wall.
- Continue this procedure until the run ends or you come to a corner.
- **A CORNER**
 - When you come to a corner, place the 2no rails in the upright towards the edge of the roof.
 - Place your next upright adjacent to the rails in the position / line it will be in on the return to the corner.
 - Place the sweeping bend on the upright and rails and mark on your cut lines accordingly to the sweeping bend. (approximately 100mm into the bend will be suffice).
 - Take both rails out and find a suitable place to cut the rails. It's advisable to mark up your cut rails to avoid them getting mixed up.
 - Once cut and marked, place the rails back into the upright. Slide the sweeping bend over the rails with bolts on the bend pointing towards the roof and tighten 2no bolts.
 - Use the 2no off cuts to slide in the return of the sweeping bend. Slide the next upright onto the off cuts and continue fixing the uprights and rails as previous.

Continued....



➤ D end

- A D end will be supplied to slide into the long upright on the finishing side.
- The D end is 500mm long and can be cut down if required.
- Tighten bolts up to secure D end

➤ Wall fixed end

- When the rails can be fixed into a wall , a wall bracket will be supplied.
- There are 4no fixing holes in the bracket, use suitable fixing for the 6mm hole.
- Into brick or concrete we advise M8 x 50's JAB fixings of 6mm threaded bar resin fixed.
- Into cladding we advise pop rivets or tek screws to be used.
- The system can end on a short or long upright when using the wall brackets, don't exceed the 2.5mtr span.

Continued



➤ ON COMPLETION

- When the Evorail system is erected. The system can be adjusted to accommodate rise and falls of the roof.
- If levelling is required, unscrew the bottom bolt on the top section of the upright and adjust accordingly.
- Re-tighten the bolt once level
- Walk round checking the system is level and in line and double checking all the bolts and fixing are tight and secure.



Tel: 01257 260441
Fax: 01257 233866
Email: info@akmfabrications.co.uk

AKM Fabrications
Unit 6, Yarrow Business Centre
Yarrow Road
Chorley
PR6 0LP

Visit our website at: www.akmfabrications.co.uk

